

THIS DRAWING IS UNPUBLISHED. RELEASED FOR PUBLICATION, 19 .
 © COPYRIGHT 19 BY AMP INCORPORATED. ALL INTERNATIONAL RIGHTS RESERVED.

LOC	DIST	P	F	ZONE	LTR	REVISIONS	DATE	APPD
AF	50				C	REV PER 0710-0165-95	5/12/95	JR/NN

IDENTIFICATION NUMBER 4 FOR MAGNET WIRE RANGE

- ① SLOT ACCEPTS 0.18-0.23mm DIA [#33-#31]AWG COPPER MAGNET WIRE
- ② 0.00203-0.00635 [.000080-.000250] TIN PLATE PER MIL-T-10727 OVER 0.00254 [.000100] MIN COPPER UNDERPLATE PER MIL-C-14550.

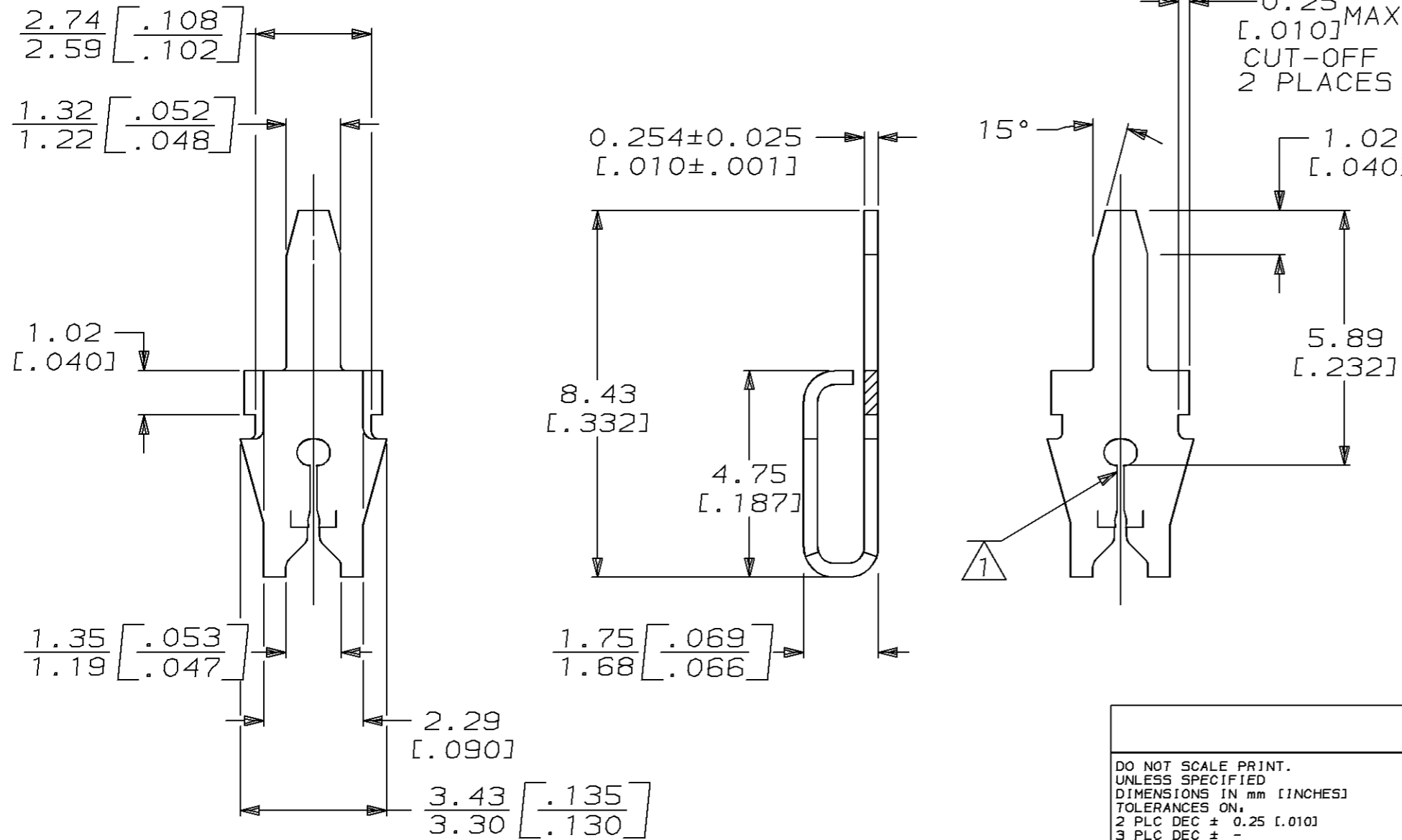

THIS DRAWING IS A CONTROLLED DOCUMENT FOR AMP INCORPORATED. IT IS SUBJECT TO CHANGE AND THE CONTROLLING ENGINEERING ORGANIZATION SHOULD BE CONTACTED FOR THE LATEST REVISION.

DO NOT SCALE PRINT. UNLESS SPECIFIED DIMENSIONS IN mm [INCHES] TOLERANCES ON: 2 PLC DEC ± 0.25 [.010] 3 PLC DEC ± - ANGLES ± -		DR 12/17/93 PHILLIP M FORTNEY	AMP AMP Incorporated Harrisburg, PA 17105-3608
MATERIAL H04 BRASS	CHK 12/17/93 MICHAEL S FEHER	NAME TERMINAL, POSTED, LOOSE PIECE, MAG-MATE™	
FINISH ②	APPD 12/17/93 NELSON E NEFF	PRODUCT SPEC 108-2012	SIZE B
	APPD 12/17/93 TERRY L SHUTTER	APPLICATION SPEC 114-2069	CAGE CODE 00779
	WEIGHT -		DRAWING NO C-62934
			SCALE 8:1
			SHEET 1 OF 1

62934-1

PART NO